

**PLAN**

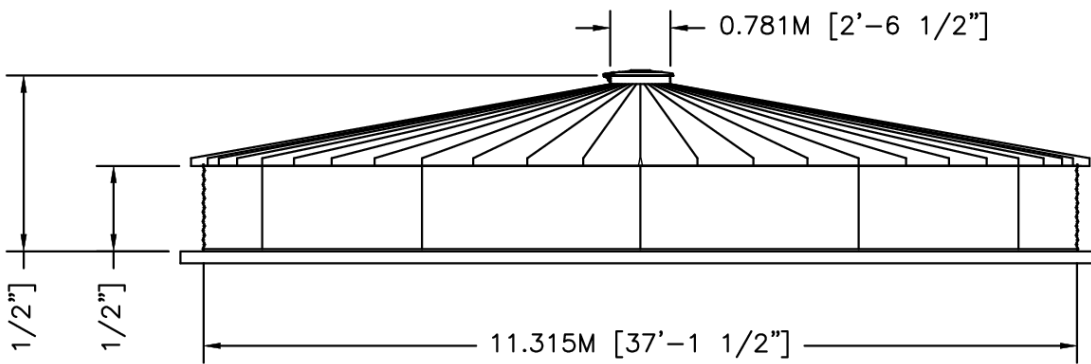

**ELEVATION**



	BY	DATE
DWN	XXX	XX/XX/XX
CKD		
ENG		

TITLE		REV. NO.
WTU12-01 30"PR 10DEG V-RIB NOMINAL CAPACITY - 98.33 M3 [25,977 GAL]		
DWG. NO.	SCT3701-LVR WTU12-01	REV. NO.
SIZE:	SCALE:	SHEET OF
A	1/8"=1'-0"	1 OF 1